

MODEL 550



Heavy Duty Slurry Seal



The **Model 550** is ideally suited for slurry applications, particularly those with harsh operating parameters, differing product consistencies, and those of a corrosive nature. It also successfully seals many bleaching materials, including multiple forms of HTH paste, as well as higher concentration caustic products. In addition, the **550** (equipped with its "pumper" option) lends itself well to hazardous waste applications, overcoming the large abrasives, varying chemicals and occasional dry-run scenarios typical to the service.

Advanced Sealing International

ASI Model 550

The **Model 550**, ASI's double slurry seal, is built to handle heavy slurries (up to 80% solids), especially those that tend to dewater in the stuffing box or plate out onto the seal components. It is a custom-fitted seal that completely fills the pump stuffing box, thereby preventing any product from entering the seal chamber while providing a controlled sealing environment. The **550's** unique design eliminates the need for special metallurgy as only the inboard seal faces and o-rings (in the bottom of the stuffing box) see the product.

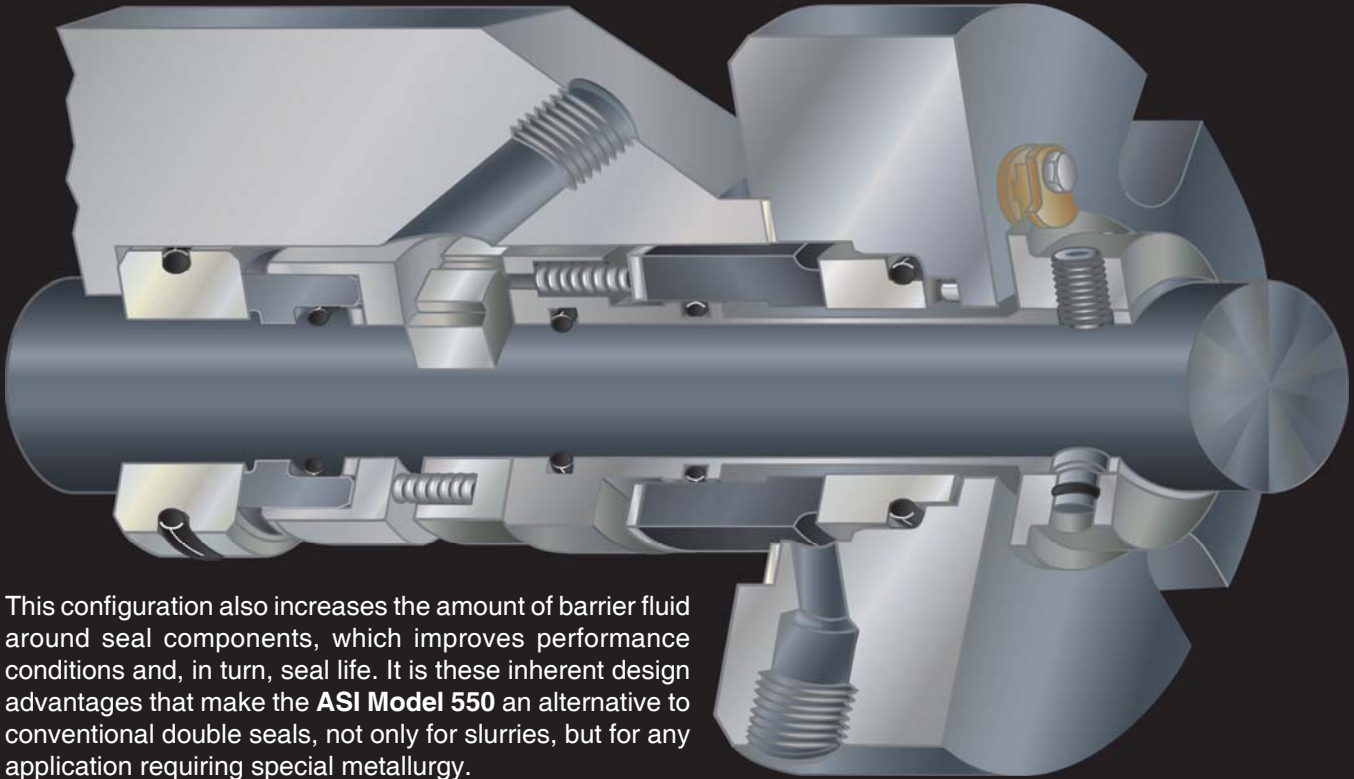

This configuration also increases the amount of barrier fluid around seal components, which improves performance conditions and, in turn, seal life. It is these inherent design advantages that make the **ASI Model 550** an alternative to conventional double seals, not only for slurries, but for any application requiring special metallurgy.

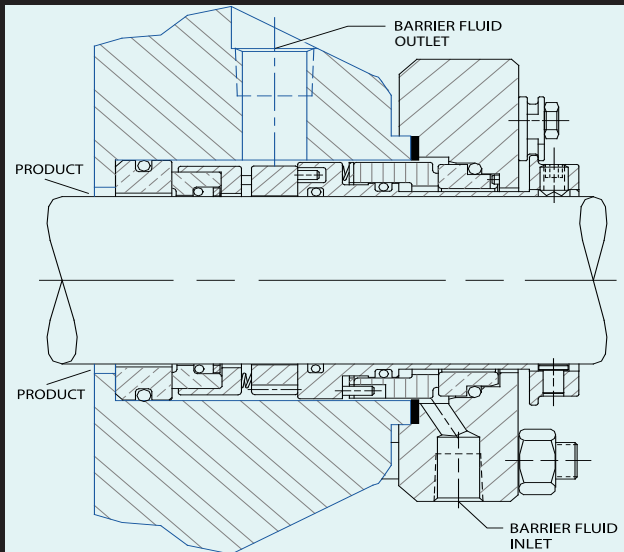

STANDARD METALLURGY- Metal components are removed from the product; expensive metal upgrades are unnecessary. Material upgrades for o-rings and faces are minimal as well.

OPTIONAL CIRCULATING DEVICE- Deep channels milled into the optional pumping ring significantly enhance the circulation of barrier fluid in the seal chamber.

CARTRIDGE MOUNTED- Seal components are driven by a single cartridge-mounted seal. This technology simplifies seal installation and allows full impeller adjustability.

RUGGED INBOARD FACES- The inboard component seal and standard stationary seat provide a rugged "hard" face combination at no added cost.

FULL SEAL REPAIRABILITY- Seal parts are fully repairable, adding even more flexibility and value to this double seal.

PUMP SPECIFIC DESIGN- The custom-built, pump specific gland plate "sets" the inboard seal length and insures that the seal completely fills the stuffing box.

MATERIALS OF CONSTRUCTION:

STANDARD FACE MATERIALS

- Inboard Stationary Face- Siliconized Graphite¹
- Inboard Rotary Face- Silicon Carbide¹
- Outboard Stationary Face- Silicon Carbide
- Outboard Rotary Face- High Quality Carbon Graphite

STANDARD METAL PARTS

- Metal Components and Set Screws- 316ss¹
- Springs- Hastelloy[®] C

SECONDARY SEALS

- Standard O-ring Materials- Viton[®], EPDM or Aflas^{®1}

¹Other Materials May Be Specified